

1955~1957 Chevy Bench Seat Relocation Brackets

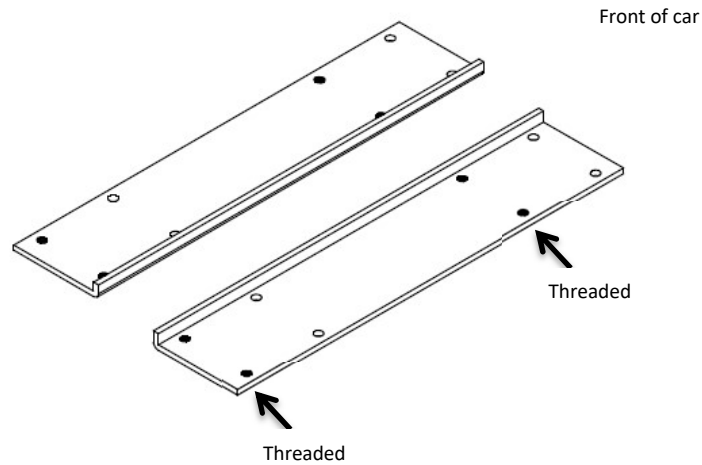

Tools needed:

1/2" & 9/16" Socket

Ratchet

1. The factory seats are bolted to the floor using four 5/16" bolts. The seat is held in place by a foot clip at the front of the seat, at the rear of the seat it bolts to the floor thru the frame of the of the seat.
2. When placing the brackets in the car make sure the non-thread holes of the bracket are positioned towards the front of the car with the lip of the bracket positioned towards the center of the car.
3. The relocation bracket is bolted to the floor using the original seat mounting locations. Line up the non- threaded holes of the bracket with those original locations and secure with the new grade 8 bolts & lock washers. **Note:** The front bolts will use the 5/16-18 x 1" threaded bolts, the rear will use the 5/16 -24 x 1" bolts.
4. Attached the front seat clip to the bracket using the 3/8"-24 x 1/2" bolts & lock washers, do not tighten completely at this time.
5. Set the seat in place making sure the front seat legs are under the seat clip.
6. The rear legs of the seat frame can now be secured in place using the remaining 3/8"-24 x 1/2" bolts & lock washers.
7. At this point all seat mounting bolts can be tightened.
8. The overhang of the bracket at the rear of the seat can be hidden under the carpet, just add a little extra padding to give a nice smooth look. Enjoy the extra leg room.